

19th AMSAT-NA Space Symposium and Annual Meeting

Decatur, Georgia. October 5-8, 2001

24 GHz Working Group Breakfast
AO-40 K Band, The Challenge

Ed Cole, AL7EB, Antonio Fernández, KC2HAX, Tom Haddon K5VH, Don Woodward, KD4APP

and special thanks to

Steve Diggs, W4EPI, Michael Fletcher, OH2AUE, Danny Orban, ON4AOD

Charlie Suckling, G3DWG

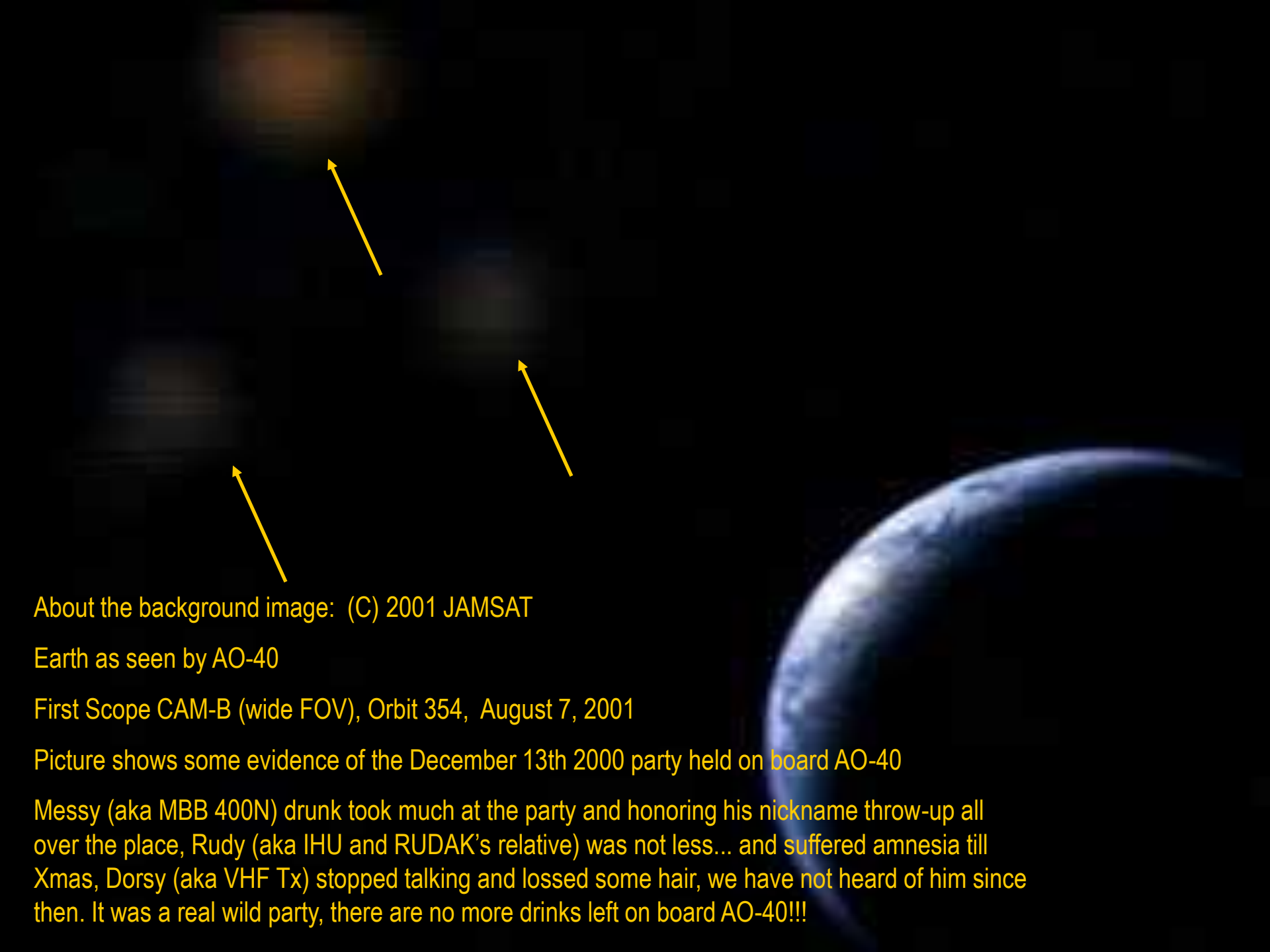

About the background image: (C) 2001 JAMSAT

Earth as seen by AO-40

First Scope CAM-B (wide FOV), Orbit 354, August 7, 2001

Picture shows some evidence of the December 13th 2000 party held on board AO-40

Messy (aka MBB 400N) drunk took much at the party and honoring his nickname throw-up all over the place, Rudy (aka IHU and RUDAK's relative) was not less... and suffered amnesia till Xmas, Dorsy (aka VHF Tx) stopped talking and lossed some hair, we have not heard of him since then. It was a real wild party, there are no more drinks left on board AO-40!!!

AO-40 K Band, The Challenge

“The addition of an S band transponder on board Phase III C will help to the average user in his transition to the microwave frequencies”

Bill McCaa, K0RZ. Designer and creator of AO-13 mode S transponder
May, 1985

- 24 GHz a Technical Challenge
 - The highest “non-optical” frequency band on an amateur satellite
 - Limited availability of equipment
 - Not many elmers
- Mode */K an Operational Challenge
 - Propagation on 24 GHz
 - A unique combination:
 - Narrow-band at extremely high microwave frequency plus
 - Narrow beamwidth to aim a moving target at 60,000 km



24 GHz Working Group Breakfast

AO-40 K Band, The Challenge

Program

- **AMSAT OSCAR-40 K Band (24GHz) Transponder**
 - **K Band Ground Station Requirements**
 - **24 GHz Narrow-band Equipment**
 - **AO-40 K Band Operations, The Challenge**
- 

The background of the slide is a dark space scene. On the right side, the curved horizon of the Earth is visible, showing a blue sky and white clouds. In the upper left, there is a bright, out-of-focus light source, likely the Sun, creating a lens flare effect. The overall color palette is dark with highlights of blue and white from the Earth and the Sun.

AMSAT OSCAR-40 **K Band (24 GHz) Transponder**

Antonio Fernandez, KC2HAX

K Band (24 GHz) Transponder



Stefaan Burger, ON4FG



Danny Orban, ON4AOD

- **Developed by AMSAT-ON**
 - Stefaan Burger, ON4FG
 - Danny Orban, ON4AOD
 - Peter Pauwels, ON1BPS
 - Philip Sanders, ON7IZ
- **Original AMSAT-ON idea was to have a 24 GHz beacon keyed in the 10.7 MHz IF**
- **Karl Meinzer, DJ4ZC suggested to build a transponder**

Assumptions used for link calculation and K band transmitter requirements

- **Signal Power**

- Path at apogee 47,000 km
- Antenna -3dB beam width 13.7deg
- Satellite Antenna gain 23 dB

- **Noise Power**

- Ground Station Rx NF ~ 2 dB
- Tsky @24GHz 50 K

- **Transponder output power**

800 mW

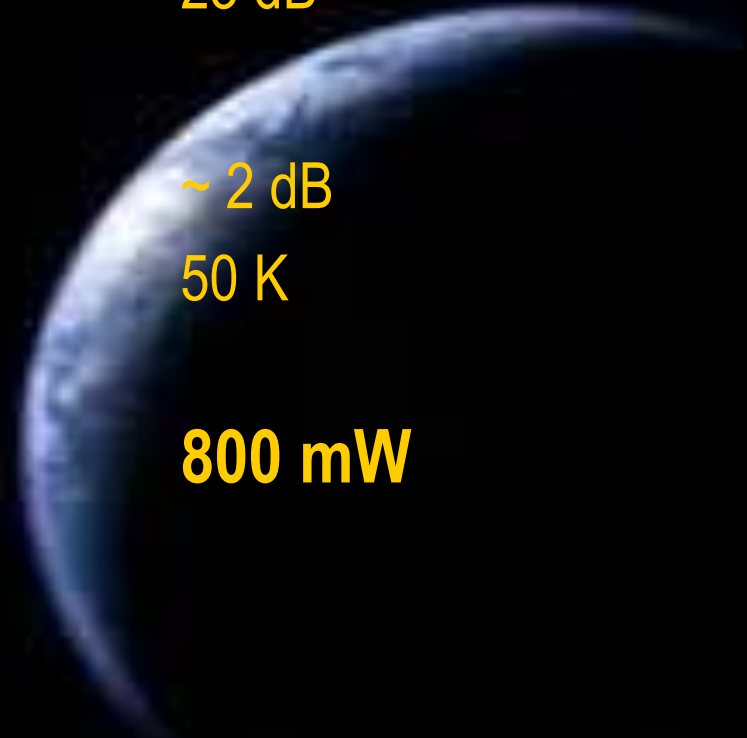

AO-40 K Band Transponder

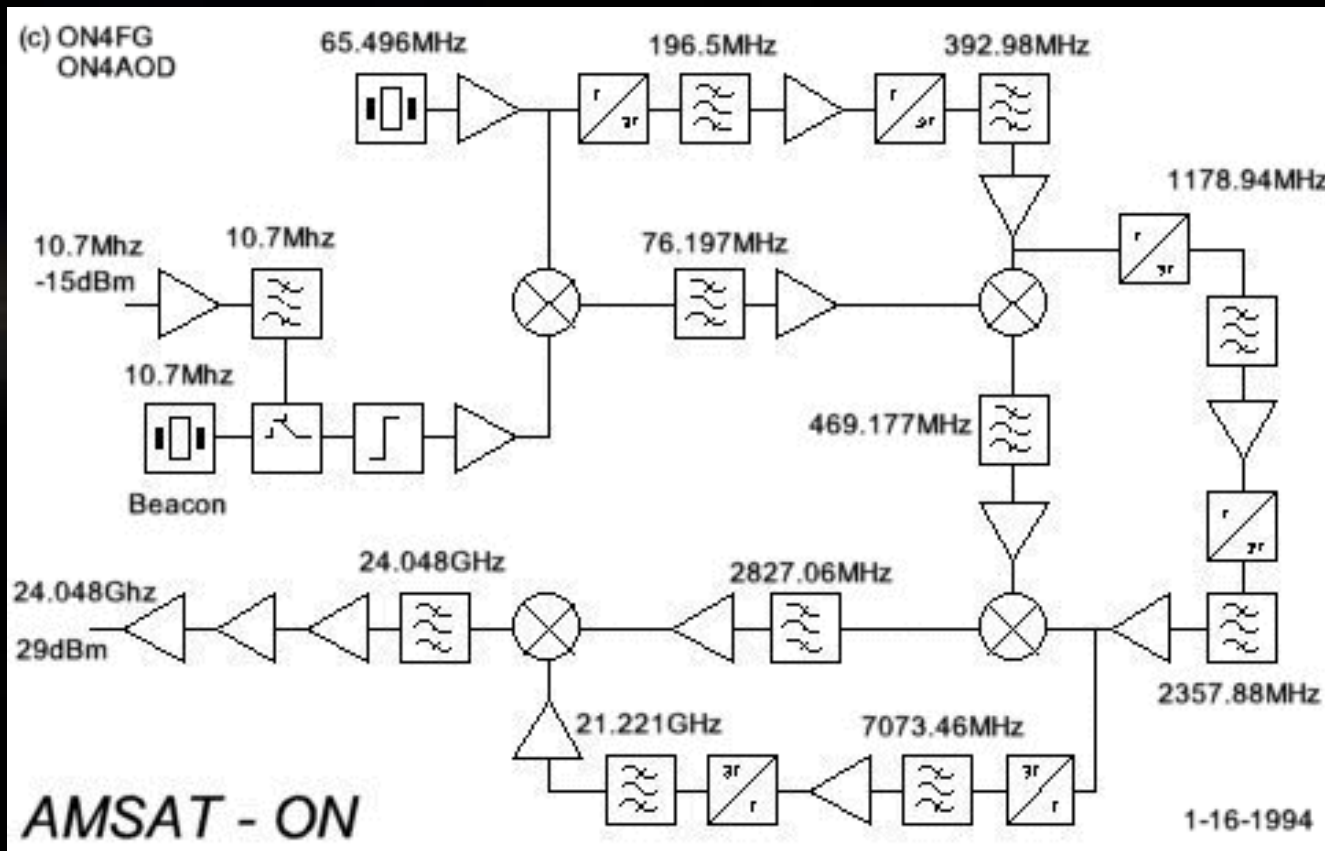

AO-40 K Band Transponder 65.496 MHz LO



Photos by Danny Orban, ON4AOD, (C) AMSAT-ON

AO-40 K Band Transponder

Lower Half, clipping circuit, IF BP filter and PS



AO-40 K Band Transponder Upper Half and PA

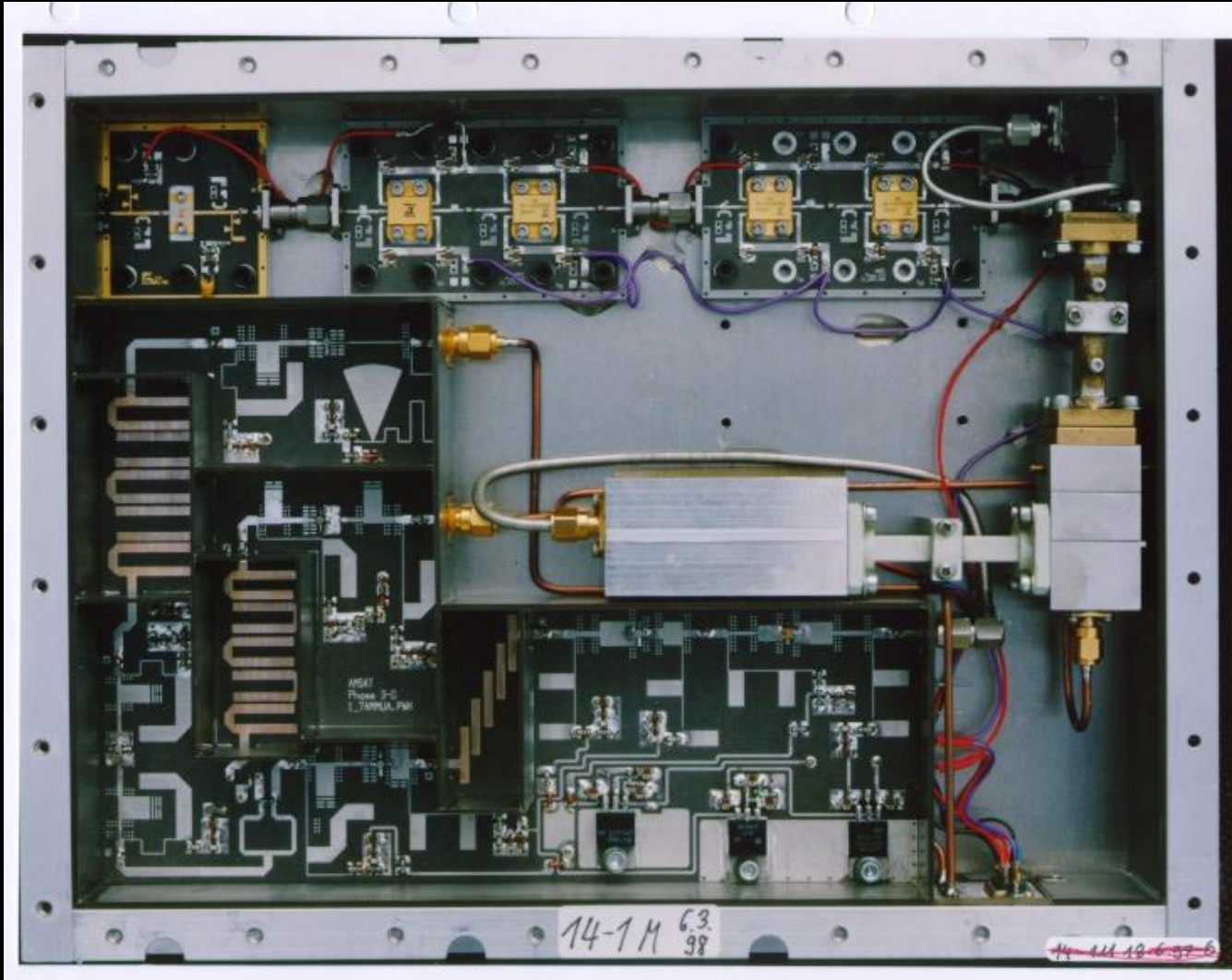

AO-40 K Band Transponder

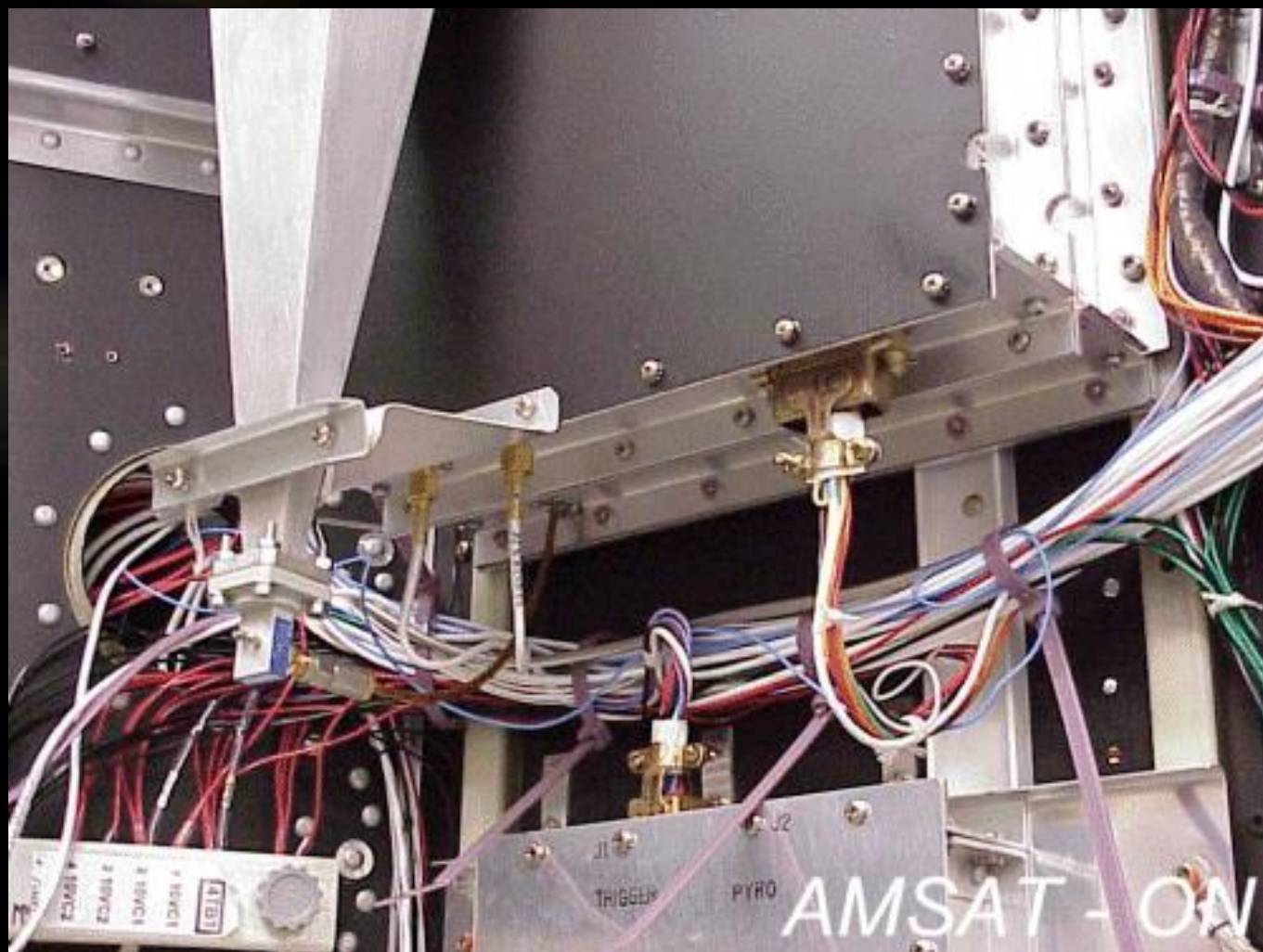

Photos by Danny Orban, ON4AOD, (C) AMSAT-ON

Down-link Budget Comparison

S2 (2.4 GHz) vs K (24 GHz)

AMSAT OSCAR-40	S2 Band 2401 MHz	Ka Band 24048 MHz	Notes
PEP Transponder	50 W	1 W	
Sat.Ant.Gain	10.5dBi	23dBi	
PEP Sat	27.5 dBWi	23 dBWi	← Actual horn gain is 26.5 dBi
PEP/QSO (-13dB ca)	14.5 dBWi	17 dBWi	3-4 QSOs K Band
Loss	195.6 dB	215.6 dB	60K km range
PEP Ground	-181 dBWi	-198.6 dBWi	
Ground Ant	20 dBi	40 dBi	
	60 cm dish	60 cm dish	
Signal power	-161 dBWi	-158.6 dBWi	Based on AMSAT-DL
Noise Temp	150K	300K	pre-launch assumptions
	1.5 dB NF	2.5 dB NF	
Noise Power SSB	-173 dBW	-170 dBW	
S/N	12.0 dB	11.4 dB	

K Band Transponder Passband

- Transponder Passband is 50 KHz
- Center Frequency (MB) is 24.048.075 MHz

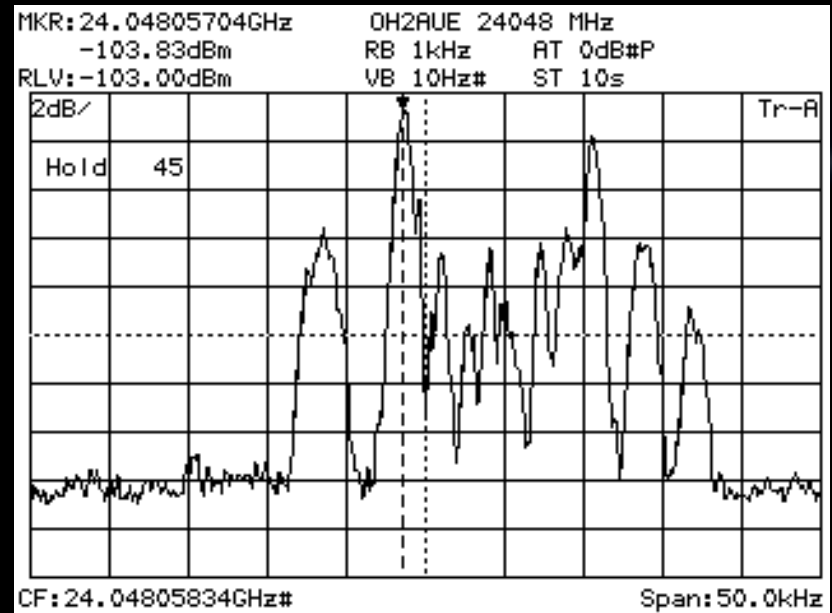
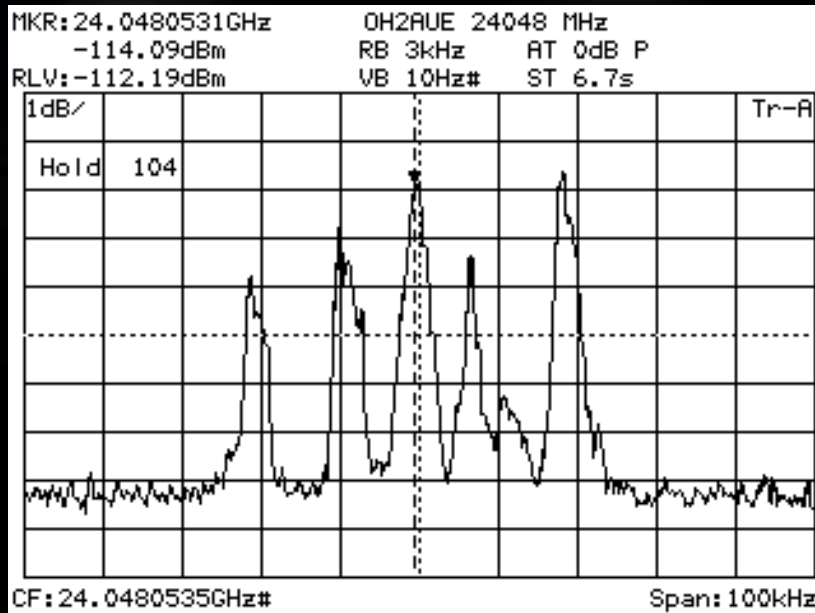

K band reception at OH2AUE. MB and pass-band signals from U and L1 receivers. Rx antenna is 60 cm dish (left) and 120 cm dish (right). Charts courtesy of Michael Fletcher, OH2AUE

K Band Ground Station Requirements

Slides for Work Group Discussion



Equipment for 24 GHz band

- Wideband
 - Wide-Band FM equipment
 - Bandwidth 30 MHz, typical
 - **This equipment is not suitable for AO-40 K Band**
 - “Gunnplexer”
 - Radar detectors
 - Intruder alarms
 - But could be very useful during the construction and/or alignment of the narrow-band K gear (e.g. tuning filters, measuring return loss, etc.)
- Narrow-band
 - Equipment suitable for CW, SSB
 - Typical Maximum Bandwidth is 2.5 kHz

AO-40 K Band Rx Ground Station

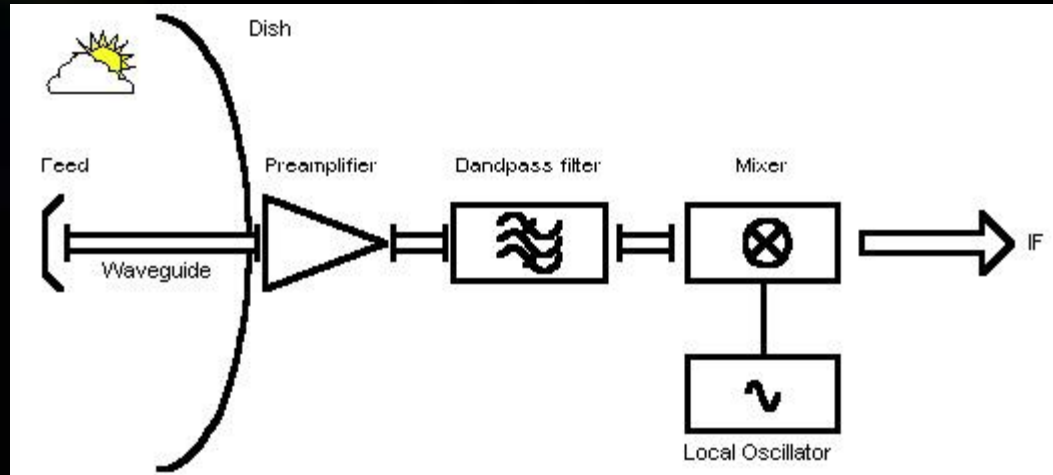

- Antenna Gain 40 dBi (dish 60-90 cm)
- Antenna Polarization
 - Circular Spin Stabilization
 - Linear 3-axis Stabilization
- Narrow-band Microwave Receiving System
- Noise Figure 2.5 dB
- Conversion Gain 30 dB

24 GHz Narrow-band Equipment for AO-40

Slides for Work Group Discussion



24 GHz Narrow-band Equipment

- **Equipment suitable for CW, SSB**
- **Typical maximum bandwidth is 2.4 kHz**
- **Narrow-band is very demanding at 24 GHz**
 - e.g. LO stability, phase noise, etc
 - If low IF's are to be used filters have to be made on WG
- **Sources**
 - **Amateur**
 - There are a few designs by DB6NT, JE1AAH and HB9MIN
 - Kuhne electronic (DB6NT), Germany
 - Procom, Denmark (dishes, feed horn, WR42 waveguide, flanges, transitions)
 - **Surplus**
 - Limited surplus equipment. Reason is not much professional use in the past due to propagation dependence on weather
 - “Grey Cube” boxes (cfr Microwave newsletter), the 24GHz version of the White boxes
 - **Professional**
 - There is new breed of MMIC (mixers, doublers, etc) designed for K and Ka bands

A 24 GHz off-the-shelf system

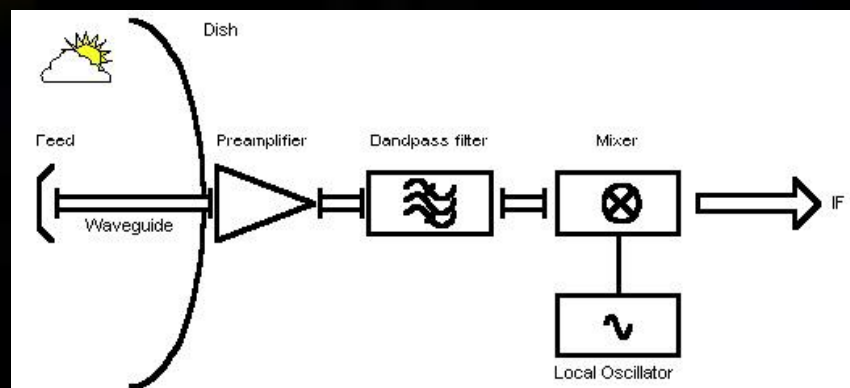

Element	Supplier, Model	Specs	Alternative Source
Dish	Procom PRO-24-002	48cm f/D .4	DSS dish
Feed	Procom PRO-24-003		Dual mode feed, W2IMU
Waveguide	Procom PRO-24-004	WR42 (R220, WG20)	
WG Flange	Procom PRO-24-006		
WG Transition	Procom PRO-24-008	WR42 to SMA-female	
Preamplifier	Kuhne MKU 243 WS	WG in-out, 30dB gain	No
Bandpass filter	Mikromecanic (DG1KBF)		Home brew
Mixer	Kuhne MKU 24 RXO	WG in, 144-146 IF	Grey Cube
LO	Kuhne MKU 12 LO	11952 MHz	G4DDK004 LO + G3WD009G multiplier

Examples of Equipment Used

Equipment	G3WDG	OH2AUE
Antenna	24 cm, 60 cm DSS	60 cm, 120 cm
Feed	Horn lineal, circular	Scalar choke ring
Preamplifier	DB6NT	DB6NT
Mixer	DB6NT Mk II	DB6NT
LO	DDK004+WDG009	DB6NT
BP filter	WDG	Adapted 22GHz Filter
Waveguide	?	WG20

The background of the slide is a dark space scene. In the upper left, there is a bright, out-of-focus star or galaxy. In the lower right, the curved horizon of the Earth is visible, showing blue oceans and white clouds. The text is centered in the upper half of the image.

AO-40 K Band Operations The Challenge

Slides for Work Group Discussion

K Band Transponder Operating Challenges

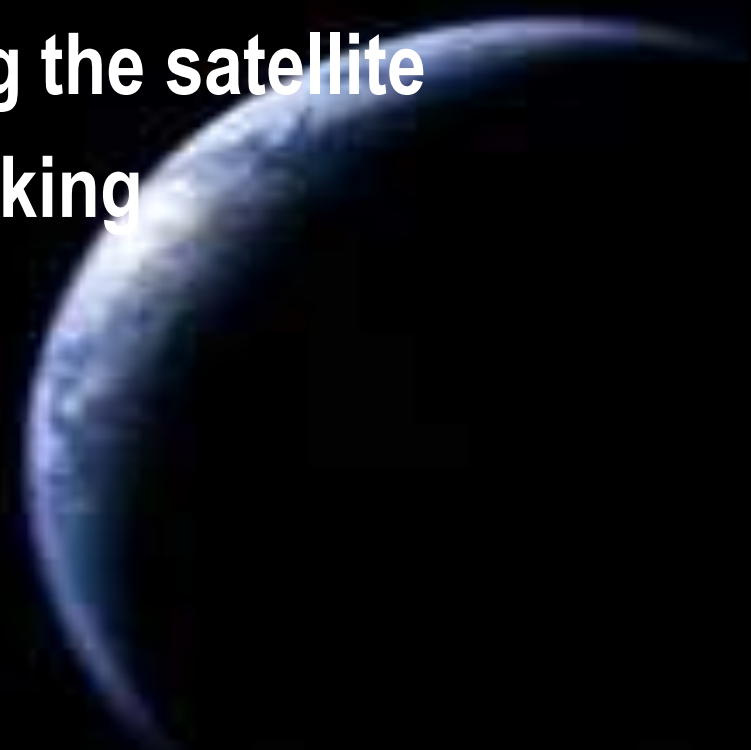
- **Weather**
 - **Antenna pointing, finding the satellite**
 - **Antenna tracking, following the satellite**
 - **Doppler, Rx frequency tracking**
- 

Atmospheric Losses @ 24 GHz Horizontal Path

- Water vapour absorption
0.15 dB/km
- Oxygen 0.01 dB/km
- Rain
1dB/km (5mm/h) to
10 dB/km (30 mm/h)

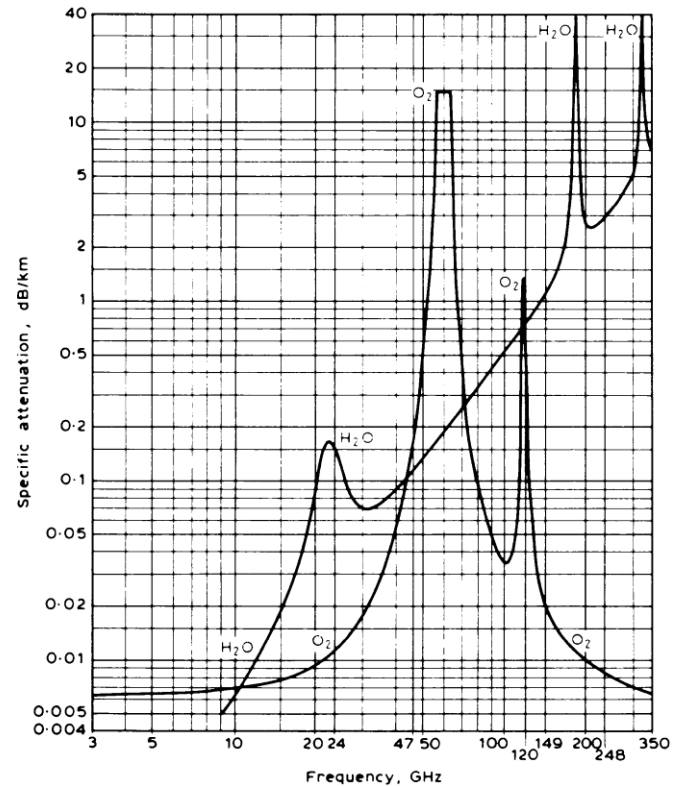
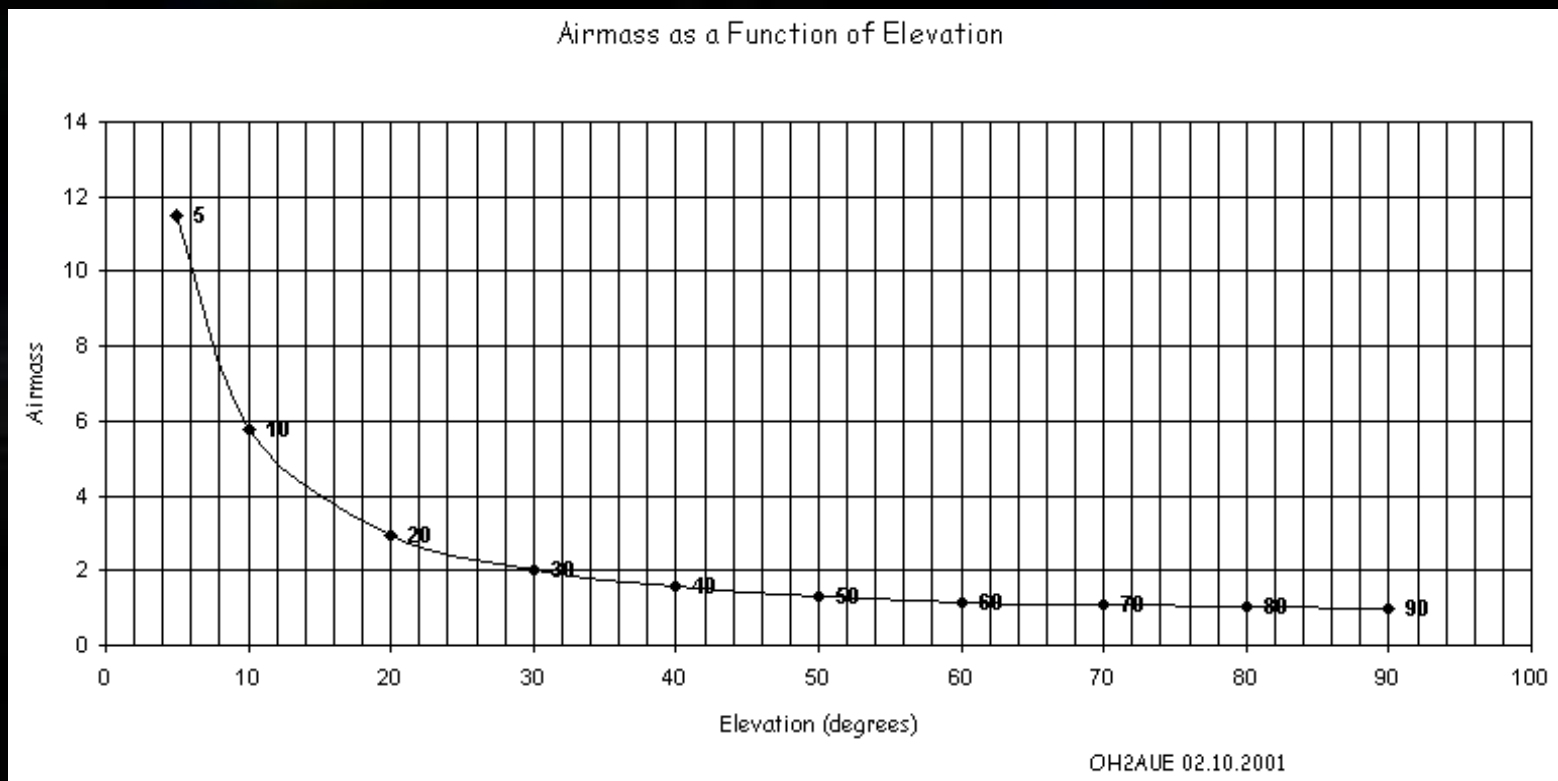

Fig 20.3. Attenuation due to oxygen and water vapour at pressure of 1 atmosphere, temperature 20°C, water vapour 7.5g/m³ (source, CCIR)

Atmospheric Losses @ 24 GHz



Air-mass decreases as a function of antenna elevation (i.e. at 20°-30° el maximal volumetric humidity would be only one km deep ~1dB) OH2AUE

Dish Antenna Comparison

S, X and K Band

Band	S	X	K
60 cm dish Gain	20 dBi	33 dBi	39 dBi
-3dB Beamwidth	15°	3.5°	1.75°
80 cm dish Gain	23 dBi	35 dBi	41 dBi
-3dB Beamwidth	11°	2.6°	1.3°
120 cm dish Gain	26 dBi	39 dBi	45 dBi
-3dB Beamwidth	7°	1.75°	0.9°

Operating hints by G3WDG and OH2AUE

Antenna Pointing and tracking

“I have the 60 cm dish on the same mount as the 10 ft S-band. Procedure is to adjust the 10 ft for max abd then the 60 is close enough to find the signals. Then optimize that. Need to touch the az/el about every 5 minutes.”

G3DWG

“Errrr... there are four unknowns in my (portable) attempts: elevation, azimuth, polarisation and frequency. As a one man operation, it is a bit of a challenge, especially at 108 m ASL :-)”

“About every couple of minutes or so to remain right on, but much less would do too.”

OH2AUE

Operating hints G3WDG and OH2AUE

Doppler at 24 GHz

“Doppler is significant, and requires fairly frequently retuning. Gets better near apogee”

G3DWG

“I am still investigating this, but there seems to be an interesting warming up feature of the TX. Anyway, the total drift over about 1.5 hours is somewhere in the order of 50 kHz, decreasing rapidly in rate towards MA138. We are still on the learning curve, mind you, but Doppler really isn't such a big issue as you might think, close to apogee .”

OH2AUE

Operating hints G3WDG and OH2AUE

Antenna polarization

“I have now modified the feed to be circular pol, with big reduction in spin fading and better copy of stations and tlm”

G3DWG

Transponder

One thing DOES come to mind that active operators of the K band TX might wonder about: the transmitter is hard limiting. This means that it is very definitely not linear, but due to the nature of the pass-band signals, SSB is quite nice to read. What the users will notice however, is that the beacon level may appear to be jumping around. This is simply due to the output power being hard distributed among users...